

# IKA

designed for scientists

**IKA Rotavisc control**

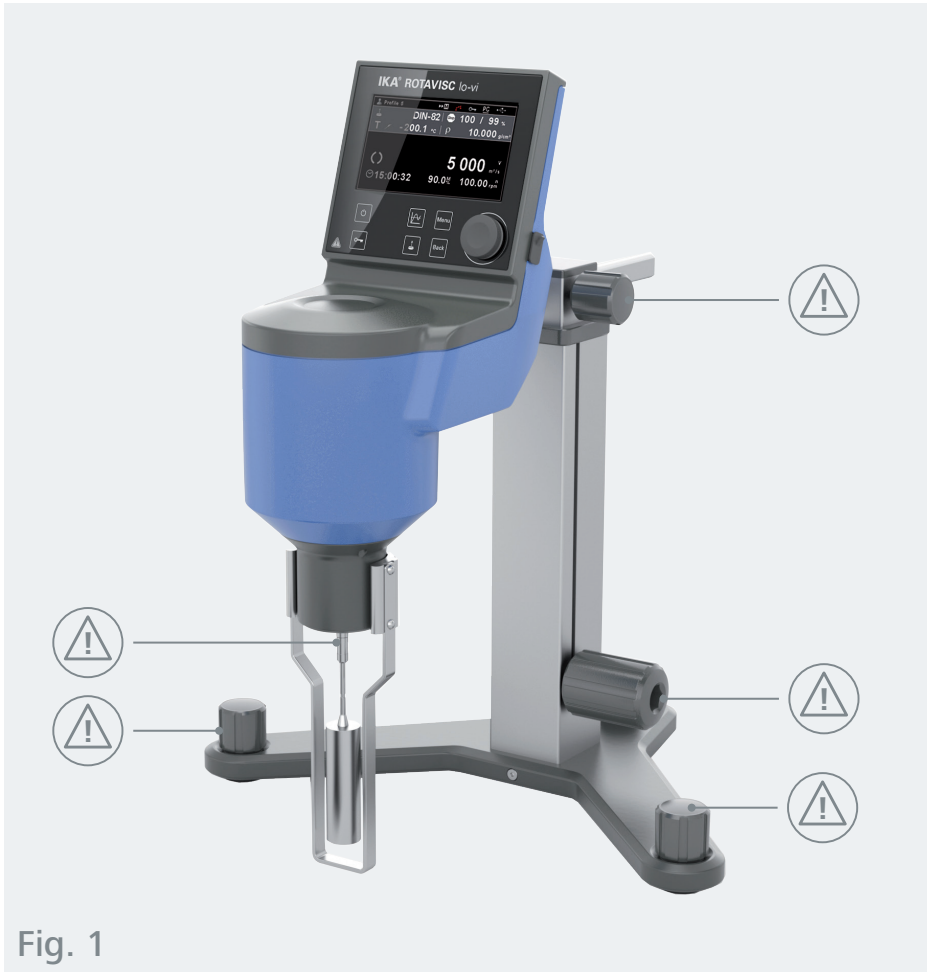

Fig. 1

ENGLISH

EU Declaration of conformity .....	6
Explication of warning symbols .....	6
/// Warning symbols.....	6
/// General Symbols.....	6
Safety instructions .....	7
/// General information .....	7
/// Device setup .....	7
/// Working with the device .....	7
/// Accessories.....	7
/// Power supply / Switching off the device .....	8
/// Maintenance.....	8
/// Disposal instructions.....	8
Intended use .....	8
/// Use.....	8
/// Area of use (only indoors) .....	8
Unpacking .....	9
Assembly .....	11
Operator panel and display .....	15
/// Explanation of the control elements.....	15
/// Explanation of symbols on the working screen.....	16
Operation .....	17
/// Switching on and leveling .....	17
/// Device self checking .....	18
/// Place the beaker and tempering bath in proper position .....	19
/// Select spindle .....	19
/// Assemble the selected spindle.....	20
/// Set the test speed (0 ... 200 rpm) .....	22
/// Start the test .....	22
Menu navigation and structure .....	23
/// Menu navigation .....	23
/// Menu structure.....	24
/// Menu details .....	25
Spindle information .....	30
Interfaces and outputs .....	31
/// USB interface.....	31
/// USB device drivers .....	31
/// RS 232 interface.....	31
/// Command syntax and format.....	31
/// Connection between the device and external devices.....	32
Error codes .....	33

Maintenance and cleaning .....	33
/// Cleaning.....	33
/// Spare parts order.....	33
/// Repair.....	34
Accessories .....	34
Technical data .....	35
Warranty .....	36
Appendix A “Range coefficient” .....	37
Appendix B “ASTM Specifications” .....	39



## EU Declaration of conformity





We declare under our sole responsibility that this product corresponds to the directives 2014/35/EU, 2006/42/EC, 2014/30/EU and 2011/65/EU and conforms with the following standards or normative documents: EN 61010-1, EN 61010-2-051, EN 61326-1, EN 60529 and EN ISO 12100.

A copy of the complete EU Declaration of Conformity can be requested at [sales@ika.com](mailto:sales@ika.com).







## Explication of warning symbols

### /// Warning symbols

-  **Danger:** Indicates an (extremely) hazardous situation, which, if not avoided, will result in death, serious injury.
-  **Warning:** Indicates a hazardous situation, which, if not avoided, can result in death, serious injury.
-  **Caution:** Indicates a potentially hazardous situation, which, if not avoided, can result in injury.
-  **Notice:** Indicates practices which, if not avoided, can result in equipment damage.

### /// General Symbols

-  **A** — Position number  
Indicates device components relevant to actions.
-  **Correct / result**  
Indicates the correct execution or the result of an action step.
-  **Wrong**  
Indicates the incorrect execution of an action step.
-  **Note**  
Indicates steps of actions that require particular attention.
-  **Beep**  
Indicates steps that audible beeps can be heard.

# Safety instructions



## /// General information

- › **Read the operating instructions completely before starting up and follow the safety instructions.**
- › Keep the operating instructions in a place where it can be accessed by everyone.
- › Ensure that only trained staff work with the device.
- › Follow the safety instructions, guidelines, occupational health, safety and accident prevention regulations.
- › The device must only be used in a technically perfect condition.

## /// Device setup

- › Set up the device in a spacious area on an even, stable, clean, non-slip, dry and fireproof surface.
- › Ensure stable assembly. The vessel used for proceeding must be secured.
- › Place the power supply outside the working area of the device.
- › All screw connections must be properly tightened.

## /// Work with the device

### **Danger!**

- › Do not use the device in explosive atmospheres, it is not EX-protected.
- › With substances capable of forming an explosive mixture, appropriate safety measures must be applied, e.g. working under a fume hood.
- › To avoid body injury and property damage, observe the relevant safety and accident prevention measures when processing hazardous materials.

### **Warning!**

- › The user should ensure that the substances under testing do not release poisonous, toxic or flammable gases at the temperatures which they are subjected to during the testing.

### **Notice!**

- › Covers or parts that can be removed from the device without tools must later be refitted to ensure safe operation. This will prevent the infiltration of foreign objects, liquids and other contaminants.
- › The device is not suitable for hand-held operation.
- › Do not touch rotating parts during operation!

## /// Accessories

- › Protect the device and accessories from bumping and impacting.
- › Check the device and accessories beforehand for damage each time when you use them. Do not use damaged components.
- › Safe operation is guaranteed only with the use of original IKA accessories.

### /// Power supply/Switching off the device

- › Disconnecting the device from the power outlet only works by removing the power supply unit from the socket.
- › The device must only be operated with the original power supply unit.
- › The outlet for the power supply must be easily accessible.

### /// Maintenance

- › The device must only be opened by trained specialists, even during repair. The device must be unplugged from the power supply before opening. Live parts inside the device may still be live for some time after unplugging from the power supply.

### /// Disposal instructions

- › The device, packaging, accessories and batteries must be disposed of in accordance with national regulations.



## Intended use

### /// Use:

- › The IKA Rotavisc must be used in conjunction with the IKA Rotastand to calculate the viscosity of a fluid at the given temperature, spindle geometry and rotation speed. The viscosity is a calculation of resistance against the fluid to flow.
- › Intended use: Stand device

### /// Area of use (only indoors):

- › Laboratories
- › School
- › Pharmacies
- › University
  
- › The device is suitable for all areas (EMC class A and B).
- › The safety of the user cannot be guaranteed:
  - If the device is operated with accessories that are not supplied or recommended by the manufacturer.
  - If the device is operated improperly or contrary to the manufacturer's specifications.
  - If the device is modified by the third parties.

# Unpacking



- > Please unpack the device carefully;
- > Any damage should be notified immediately to the shipping agent (post office, railway network or logistics company).

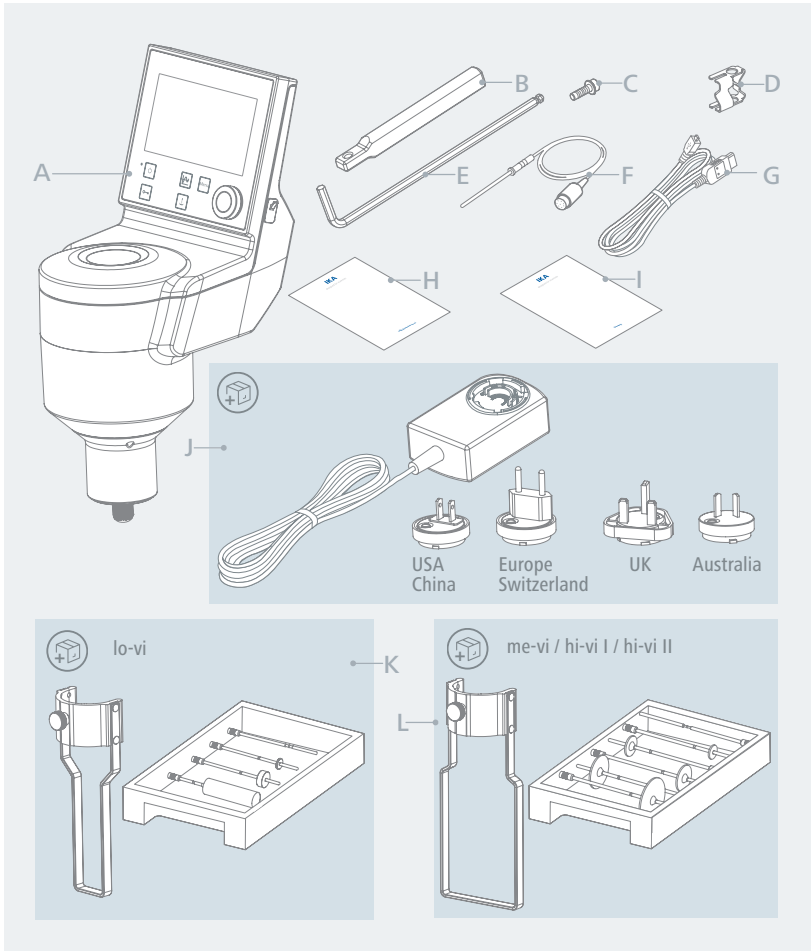

<b>A</b>	Rotavisc
<b>B</b>	Extension arm
<b>C</b>	Hexagon socket screw
<b>D</b>	Temperature sensor clamp
<b>E</b>	Screwdriver (AF = 4 mm) DIN ISO 2936
<b>F</b>	Temperature sensor

<b>G</b>	USB cable
<b>H</b>	User guide
<b>I</b>	Warranty card
<b>J</b>	Power supply unit
<b>K</b>	Guard rail / Spindle set (Rotavisc lo-vi)
<b>L</b>	Guard rail / Spindle set (Rotavisc me-vi/hi-vi)

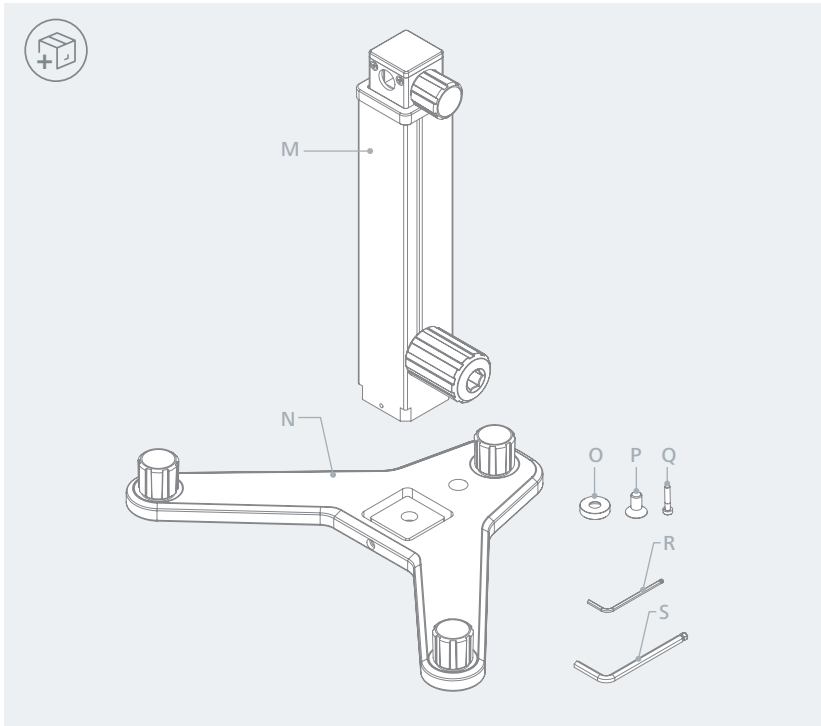

<b>M</b>	Rotastand pillar
<b>N</b>	Rotastand base
<b>O</b>	Screw washer
<b>P</b>	Hexagon socket screw (M8)

<b>Q</b>	Hexagon socket screw (M4)
<b>R</b>	Screwdriver (AF = 2.5 mm) DIN ISO 2936
<b>S</b>	Screwdriver (AF = 5 mm) DIN ISO 2936

# Assembly



1

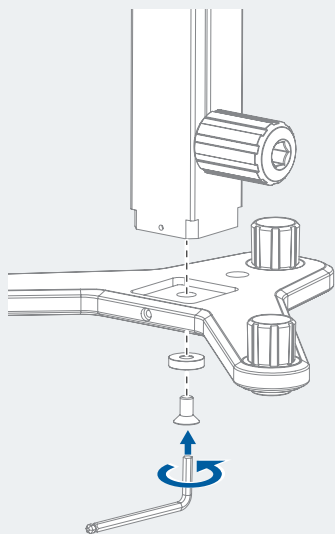

2

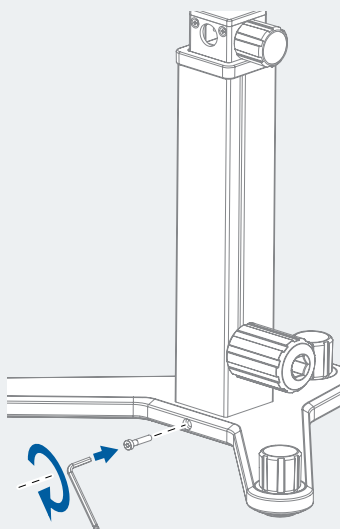

3

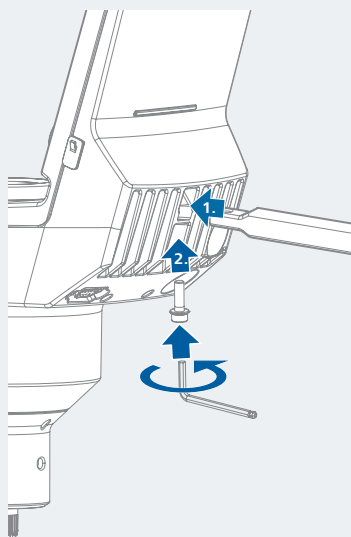

4

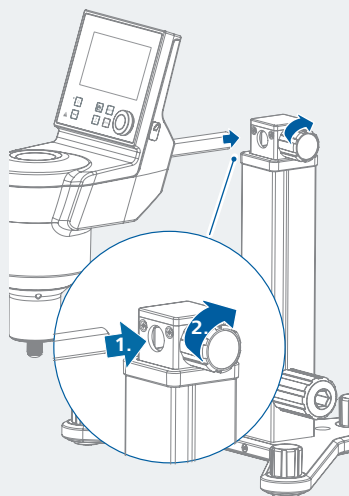

5

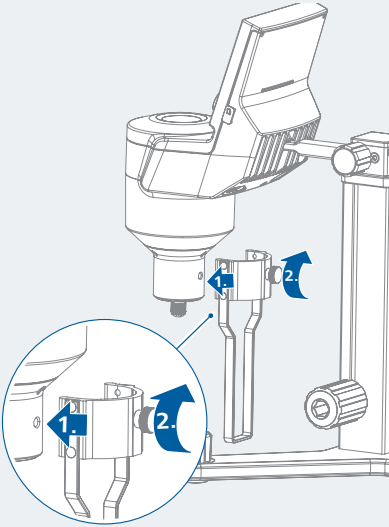

6

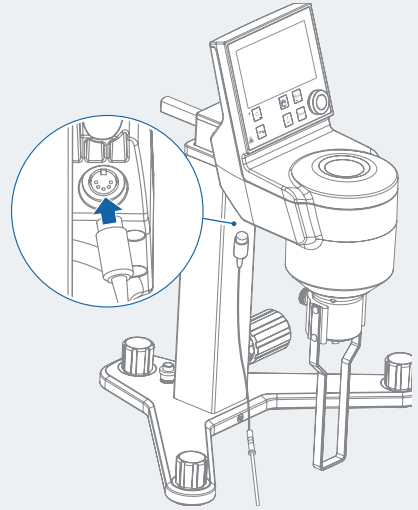

7

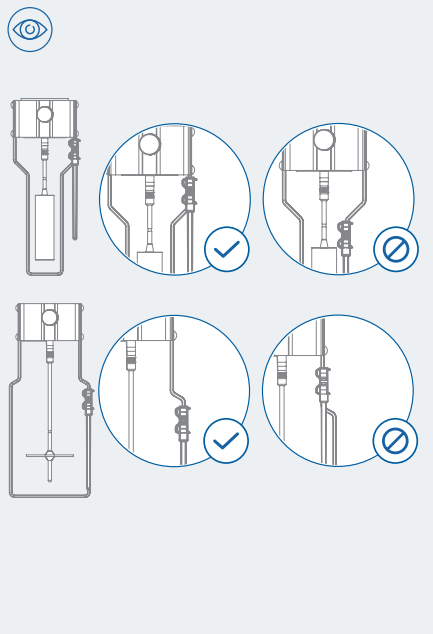
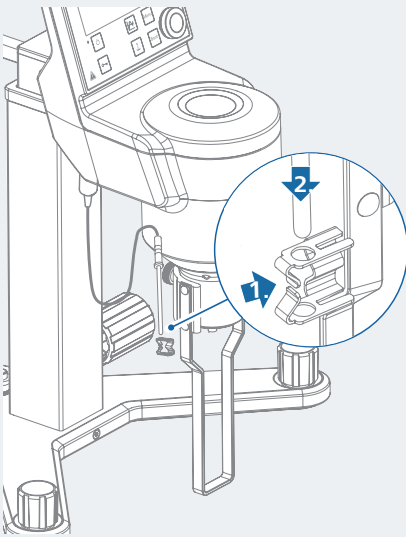

8

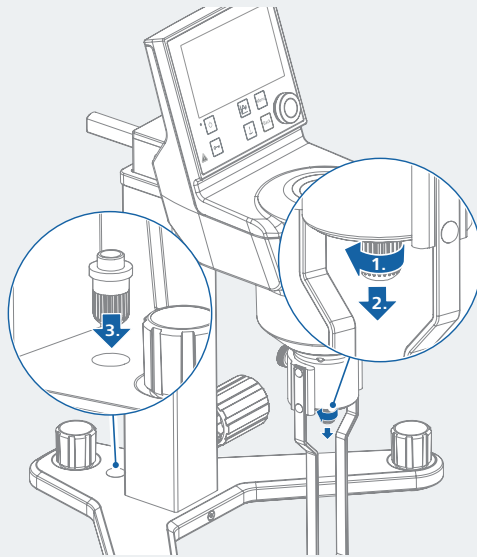

**Note:** The protection cap protects the coupling nut and the inside pivot from damage during transportation. Keep the protection cap in the hole of the stand in order to avoid missing!

9

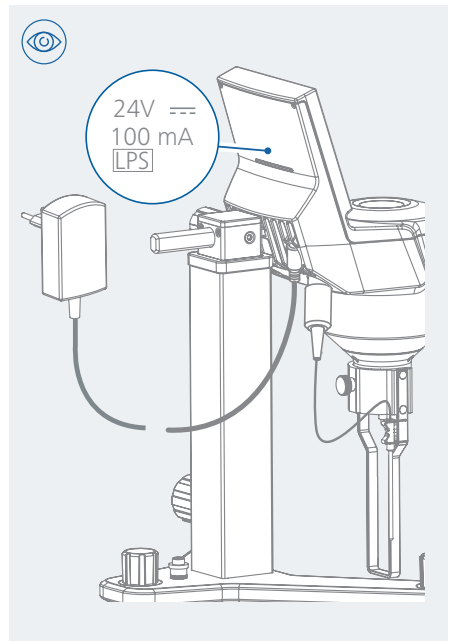
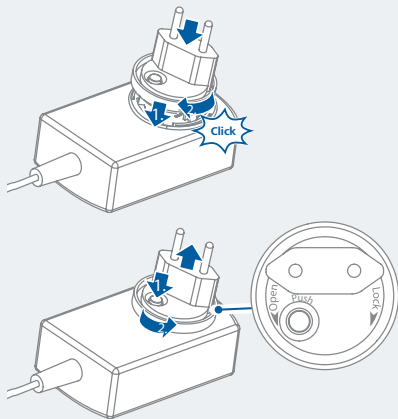



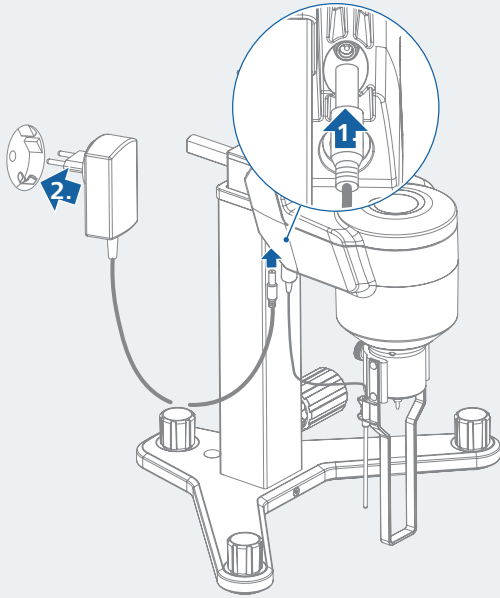

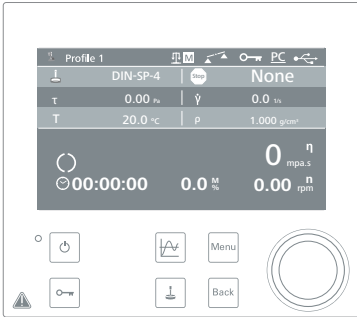

10













# Operator panel and display



/// Explanation of the control elements:

Button	Designation	Function
	Lock button	Lock / Unlock buttons and control knob
	On / Off button	Switch on / off device.
	Spindle button	Enter spindle search screen menu directly
	Graph button	Enter profile graph menu directly
	Back button	Return to previous screen
	Menu button	Touch it once: Enter main menu screen Touch it a second time: Back to working screen.
	Control knob (Rotating /Pressing)	Start / Stop the motor for measuring pressing the knob in working screen. Change the speed by rotating the knob in working screen. Change the menu setting / value in menu screen.

### /// Explanation of symbols on the working screen:

Symbol	Designation	Function
	Profile symbol	Indicate the selected profile.
	Accurate mode symbol	Indicate the accurate mode is selected.
	Balanced mode symbol	Indicate the balanced mode is selected.
	Fast mode symbol	Indicate the fast mode is selected.
	Level broken symbol	Indicate the device is no longer level.
	Lock symbol	Indicate the buttons and control knob is locked.
<b>PC</b>	PC control symbol	Indicate the device is controlled by a PC.
<b>RMP</b>	Ramp control symbol	Indicate the device is in ramp control mode.
	USB connection symbol	Indicate the device is communicating via USB
	Spindle symbol	Indicate the selected spindle
	Stop condition symbol	Indicate the stop condition
$\tau$	Shear stress symbol	Indicate the measured shear stress of the media.
$\dot{\gamma}$	Shear rate symbol	Indicate the measured shear rate of the media.
<b>T</b>	Temperature symbol	Indicate the measured temperature of the media.
$\rho$	Density symbol	Indicate the density of the media.
	Running symbol	Indicate the device is in running status.
	Timer symbol	Indicate the timer function is activated.

# Operation

/// Switching on and levelling:



1

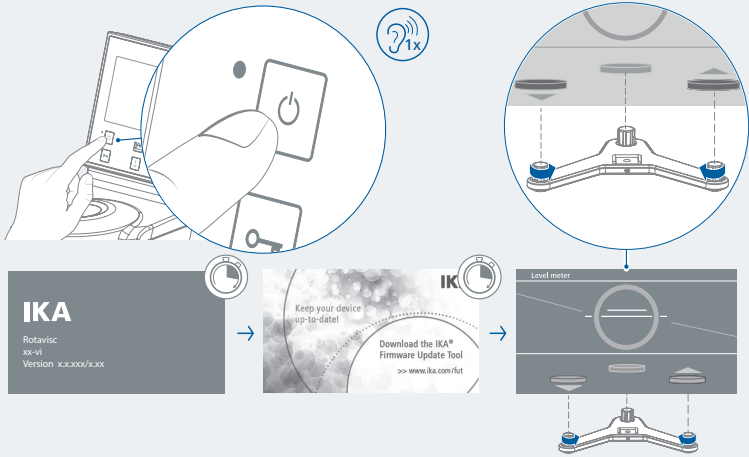

2

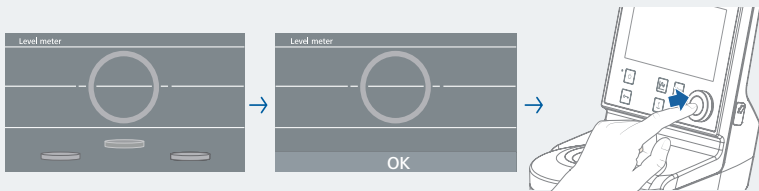

**Note:** The short horizontal white line inside the circle is moving vertically and it represents the rotation around the Y-axis. When it matches the white line, the device will be in balance with the Y-axis, then the line color will turn from white to green.

The three buttons represent the three stand levelers. The arrows show in which direction they have to be adjusted (green = up; red = down).

The other two moving lines:

The red angular line pivoting around the center of the circle represents the rotation of the device around the X-axis. When the line is horizontal (matching the white line), the device will be in balance with the X-axis, and then the line color will turn from red to green.

/// Device self checking:

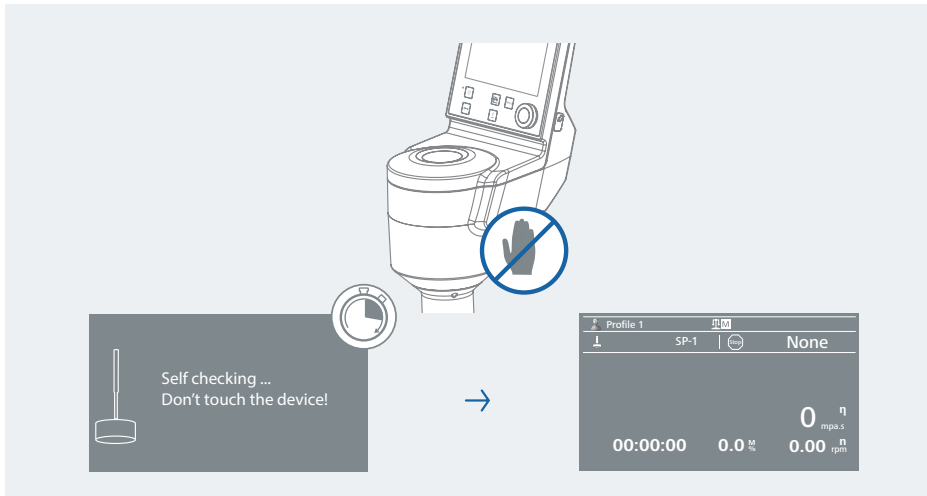
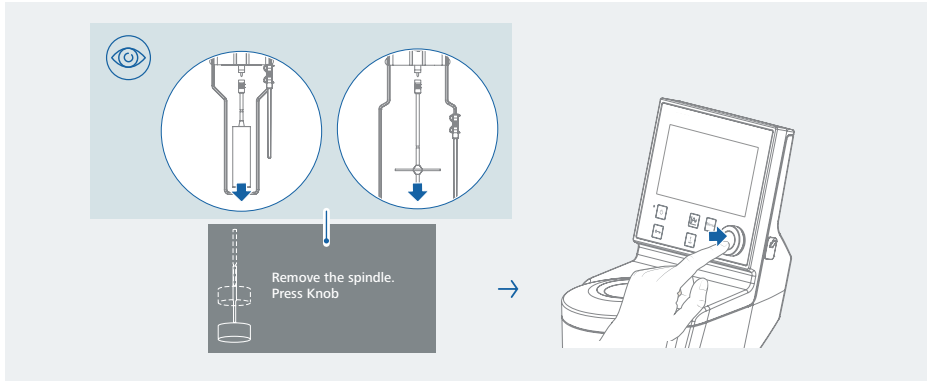

/// Place the beaker and tempering bath in proper position:

**Note:** Secure the beaker with beaker holder!

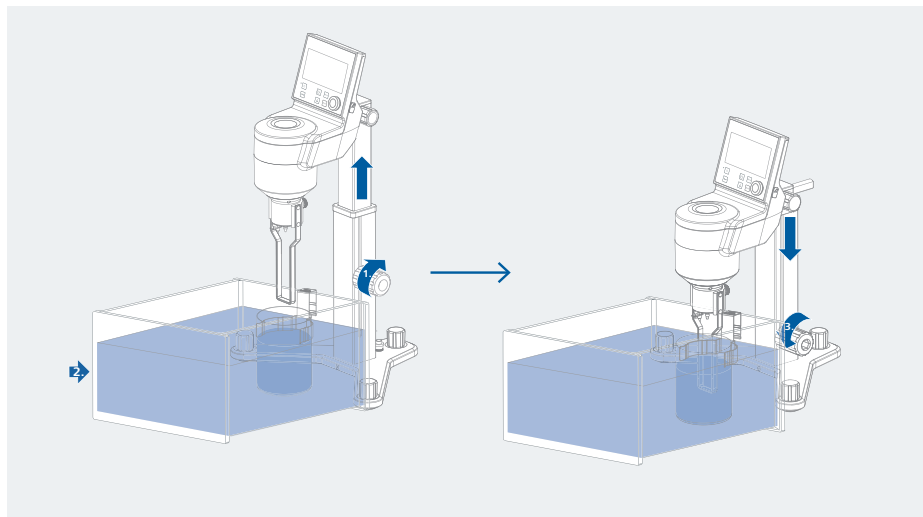

/// Select spindle:

1

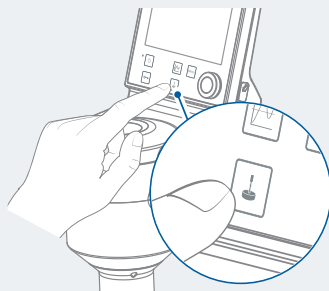

➤ Viscosity > Spi Search	
Spindle	<b>SP-1</b>
Speed	<b>28.20</b> rpm
Maximum Viscosity	<b>2269</b> mpa.s
Accuracy	<b>22</b> mpa.s

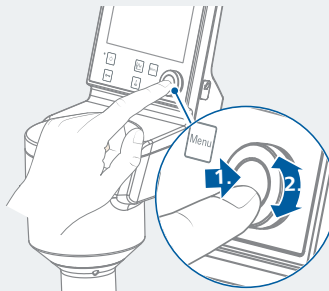

➤ Viscosity > Spindle Search	
Spindle	<b>SP-4</b>
Speed	<b>28.20</b> rpm
Maximum Viscosity	<b>226950</b> mpa.s
Accuracy	<b>2269</b> mpa.s

2

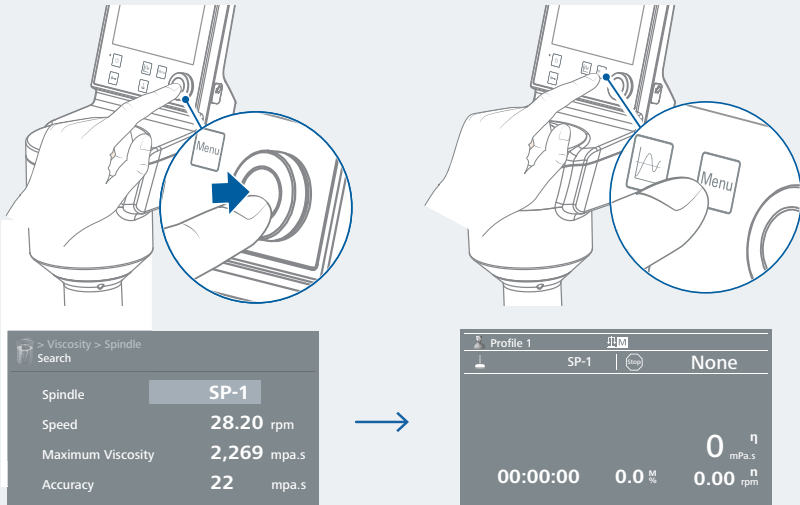

/// Assemble the selected spindle:

**⚠ Notice!**

The motor should be switched off whenever the spindle is being removed or attached. Secure and slightly lift the coupling shaft with one hand and screw the spindle (left-hand thread) with the other hand.

In order to avoid air bubbles on the spindle, tilt and immerse the spindle into the fluid before screwing it.

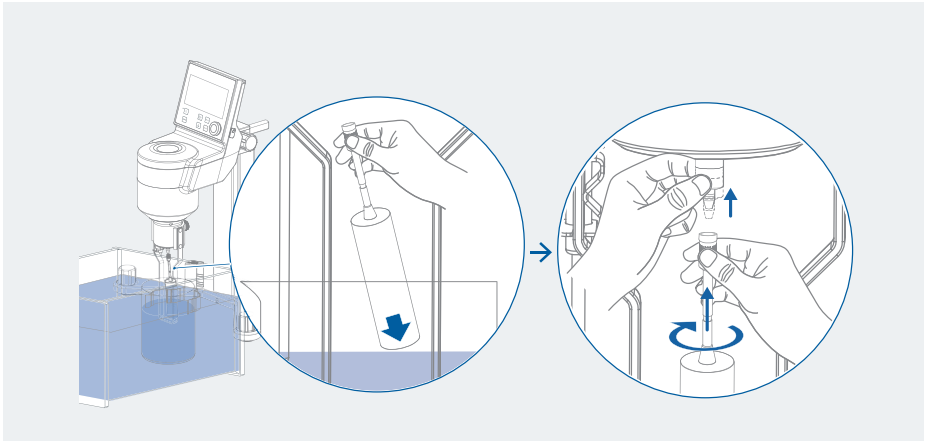

**Note:** In order to get an accurate value, keep the test condition as below:

- › Standard low form beaker: 600 ml
- › Constant temperature
- › No air bubbles attach on the spindle
- › Fluid in the beaker reaches the indentation on the spindle shaft
- › Spindle bottom surface to beaker bottom > 10 mm
- › If a thermostat bath is used, the bath fluid should over the beaker fluid about 10 mm
- › Optimum torque trend range:  $10\% < \frac{M}{M} < 100\%$ .

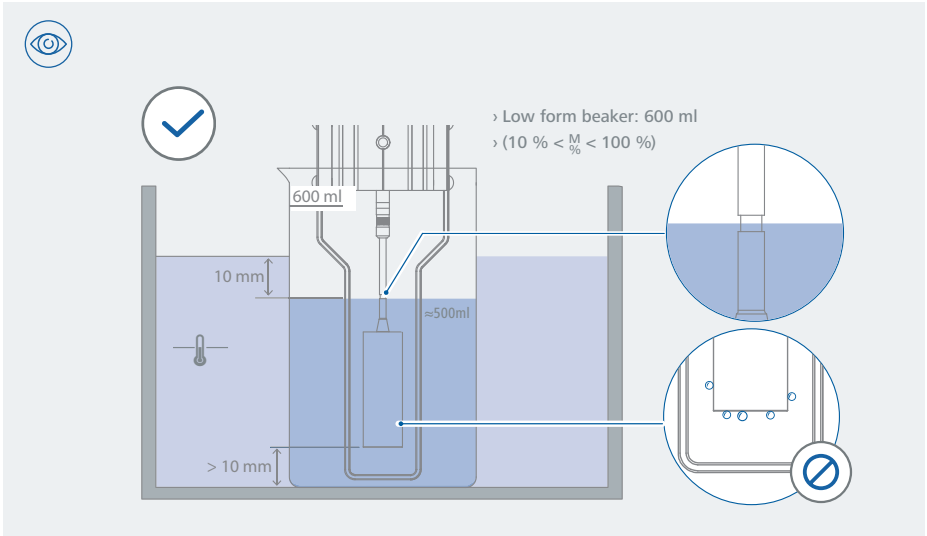

### /// Set the test speed (0 ... 200 rpm):

**Note:** Select the speed according to the viscosity of the test medium and the selected spindle. No turbulence may occur in the test medium.

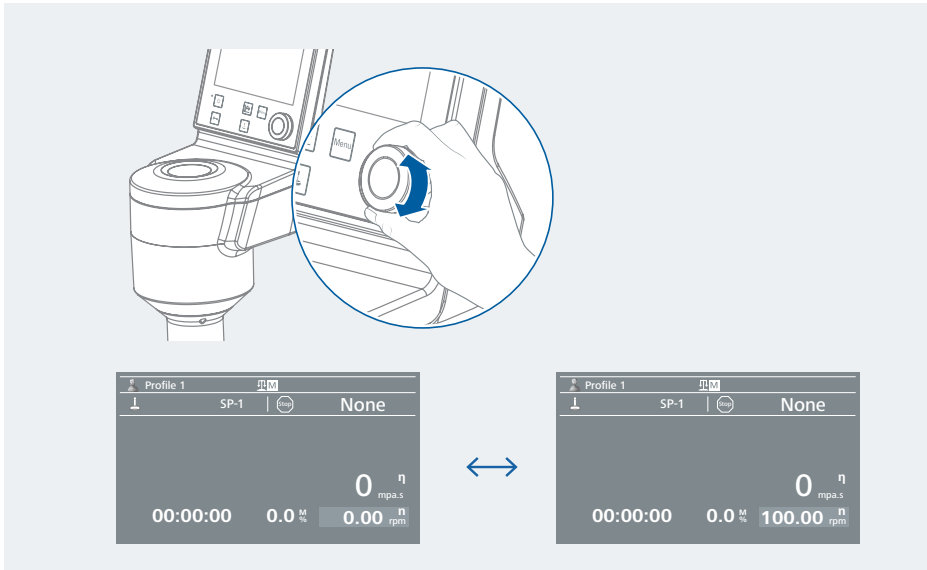

### /// Start the test:

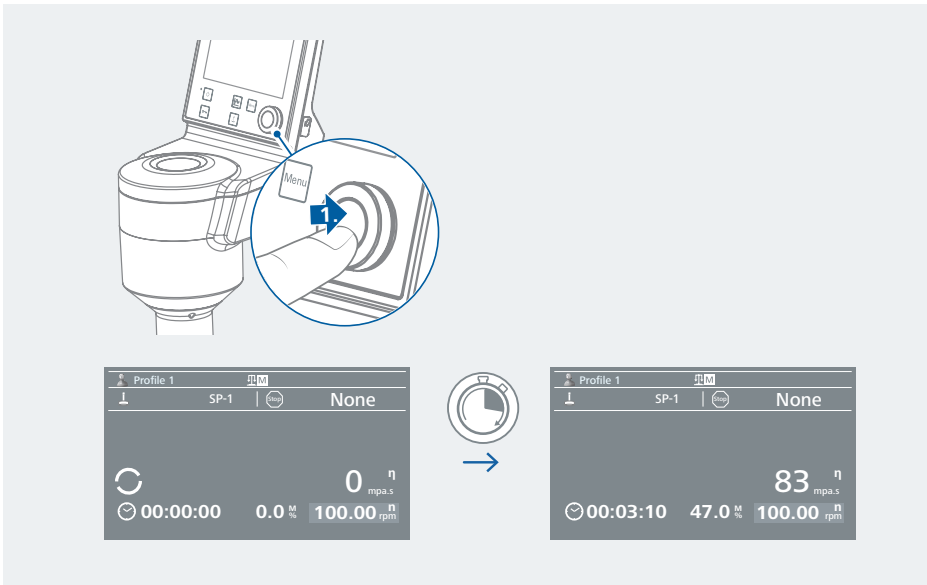

# Menu navigation and structure



## /// Menu navigation

- › Press the "Menu" button.
- › Select the menu by rotating the control knob to select the desired menu or sub-menu, which can then be selected by pressing the control knob.
- › Press or turn the control knob again to select the desired menu option and edit the values or settings, or activate/deactivate a function.
- › Rotate the control knob to "OK" or press the "Back" button or "Menu" button to end the procedure and return to the previous menu.

**Note:** The menu option activated is highlighted blue on the screen.

**Navigation menu:** → Press the "Menu" button and turn the control knob.  
← Press the "Back" button or the "Menu" button.

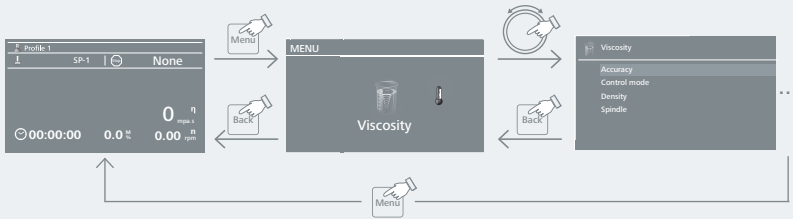

**Note:** If you press the "Menu" key, the system skips directly back to the working screen.  
If you press the "Back" key, the system skips back to the previous display.

# /// Menu structure

			Factory setting	
<div style="border: 1px solid black; padding: 2px; width: 20px; height: 20px; margin: 0 auto; display: flex; align-items: center; justify-content: center;"> </div>	Viscosity	Accuracy		
		Accurate .....	✓	
		Balanced .....	-	
		Fast .....	-	
		Control mode		
		Automatic .....	-	
		Manual .....	-	
		Density .....	1.000 g/cm <sup>3</sup>	
		Spindle		
		List		
		Standard spindle		
		SP-1 .....	✓	
		SP-2 .....	-	
		... ..	-	
		SP-12 .....	-	
		Spiral	S-S-P .....	-
		ELVAS	ELVAS-SP .....	-
		DIN		
		DIN-SP-5 .....	-	
		DIN-SP-6 .....	-	
		DIN-SP-7 .....	-	
		VOL		
		VOL-SP-2.1 .....	-	
		VOL-SP-3.8 .....	-	
		... ..	-	
VOL-SP-9.4 .....	-			
VAN				
VAN-SP-1 .....	-			
VAN-SP-2 .....	-			
... ..	-			
VAN-SP-4 .....	-			
Search				
Spindle .....	SP-x			
Speed .....	x.xx rpm			
Maximum viscosity .....	0 mPa·s			
Accuracy .....	0 mPa·s			
<div style="border: 1px solid black; padding: 2px; width: 20px; height: 20px; margin: 0 auto; display: flex; align-items: center; justify-content: center;"> </div>	Temperature	Probe temperature .....	-	
		Display .....	-	
		Calibration		
Actual temperature .....	25.5 °C			
Measuring temperature .....	25.5 °C			
<div style="border: 1px solid black; padding: 2px; width: 20px; height: 20px; margin: 0 auto; display: flex; align-items: center; justify-content: center;"> </div>	Display	Temperature .....	-	
		Level meter .....	-	
<div style="border: 1px solid black; padding: 2px; width: 20px; height: 20px; margin: 0 auto; display: flex; align-items: center; justify-content: center;"> </div>	Graph	Axis assignment		
		Shear rate .....	-	
		Shear stress .....	-	
		Speed .....	-	
		Temperature .....	✓	
		Torque .....	-	
		Viscosity .....	✓	
Time .....	-			
Axis scale .....	-			
<div style="border: 1px solid black; padding: 2px; width: 20px; height: 20px; margin: 0 auto; display: flex; align-items: center; justify-content: center;"> </div>	Programs	Program		
		Program 1 .....	-	
		Program 2 .....	-	
		... ..	-	
		Ramp		
		Ramp 1 .....	-	
		Ramp 2 .....	-	
		... ..	-	
		Stop condition		
		Timer .....	00:00:00	
		Torque		
		Higher limit .....	0 %	
		Lower limit .....	0 %	
Temperature				
Higher limit .....	0 °C			
Lower limit .....	0 °C			
Viscosity .....	0 mPa·s			
None .....	✓			

Profile	Profile 1	✓		
	Profile 2	-		
	...	-		
Safety	Password	000		
Settings	Language	English	✓	
		German	-	
		...	-	
	Unit	Temperature	°C	✓
			°F	-
		Viscosity	mPa·s - Dyn Visc	✓
			m <sup>2</sup> /s (SI) - Kin Visc	-
		cP - Dyn Visc	-	
		cSt - Kin Visc	-	
	Display	Background	Black	✓
			White	-
		Firmware Update Screen	-	
	Sound	Volume	100	
Factory Settings				
Communication	Device Name	Rotavisc		
Information	Viscosity	Control mode	Manual	
		Density	1.000 g/cm <sup>3</sup>	
		Spindle	SP-x	
	Software	Version	x.x.xxx/x.xx	
		Firmware Update Screen	x.x.xxx/x.xx	

/// Menu details:



### Viscosity:

#### Accuracy:

In this menu, you can select different measuring modes.

1. Accurate: Provides higher accuracy on measuring result but needs longer measuring time.
2. Balanced: Provides a balanced measuring accuracy and measuring time.
3. Fast: Provides a fast measuring but with lower accuracy.

#### Control mode:

In this menu, you can select different control modes.

1. Automatic: After you select the required spindle, the device will find a suitable measuring speed.
2. Manual: You need select required spindle and also set a suitable measuring speed.

#### Density:

In this menu, you can set the fluid density from 0 to 9.999 g/cm<sup>3</sup> for kinematic viscosity measuring.

### Spindle:

In this menu, you can select a required spindle for measuring.

1. List: According to the rough viscosity of the media to select a required spindle from the spindle list under different spindle groups (Standard spindle, Spiral, ELVAS...). A tick (✓) show the selected spindle and group.
2. Search: According to required speed and rough viscosity of the media to select a required spindle.

**Note:** The maximum viscosity (full scale range) can be automatically calculated basing on the selected spindle, the speed and the integrated spring series (lo-vi/me-vi/hi-vi I/hi-vi II).



### **Temperature:**

#### Probe Temperature:

In this menu, you can check the temperature of the media when the temperature sensor is connected.

#### Display:

In this menu, you can specify the measured temperature value on the screen. A tick (✓) show that the option is activated.

#### Calibration:

In this menu, you can calibrate the connected temperature sensor with help of an external standard reference temperature thermometer.

**Note:** The temperature sensor must be calibrated whenever it is replaced or changed, or if a new temperature sensor is installed. The temperature sensor supplied with the system is calibrated in factory.



### **Display:**

#### Temperature:

In this menu, you can specify the measured temperature value on the screen. A tick (✓) show that the option is activated.

#### Level meter:

In this menu, you can check the levelling status of the device.



### **Graph:**

#### Axis Assignment:

In this menu you can select 2 parameters from the 7 options (shear rate, shear stress, speed...) for axis assignment. The ticks (✓) show that the options that are activated. The selected parameters will be used for the graph in the profile.

#### Axis scale:

When parameter "Time" is not selected, the menu option "Axis scale" is disabled and shown in grey color. When you select "Time" as one axis, the "Axis scale" gets enabled and can be edited. You can select 15, 30, 60 or 120 minutes as the axis scale. The selected scale will be used for the graph in the profile.



## Program:

### Program:

In this menu, 5 user-defined “speed-time” profiles can be created. A program can consist of up to 10 segments. Once a program has been selected, the following options are available:

#### 1. Start:

Starts the program upon request of loop mode.

Infinite loop: Upon completion of the last segment, the program continues with the first segment until the user ends the program by stopping a device function.

Loop count: Indicates the total number of loop cycles until program end.

When the selected program is started by pressing on menu option “Start” with rotary/push knob, screen reminds the user to confirm the program (PR) control. Press “OK” with rotary/push knob to start the program control.

**Note:** At the end of the program all device functions are switched off.

#### 2. Edit:

Edit/change the selected program by pressing on the button “Edit” with rotary/push knob.

Start to edit the selected program parameters (speed and time ) by pressing on the selected program. You can “Edit”, “Delete”, “Insert” and “Save” the program segment with the rotary/push knob.

When you edit the program for at least one segment, symbol (  ) for respective program will appear.

In a program, user can define up to 10 program segments. The selected program segment is highlighted in blue color. Then, the user can edit, delete, insert or save segment in this program by rotating/pressing on the rotary/push knob.

When editing a parameter (Speed / Time), press the rotary/push knob on the selected parameter. The highlighted cursor changed into yellow color indicate that parameter can be edited by rotating the rotary/push knob.

When the “Back” button is pressed after editing, the program is saved after pressing on “OK” as reminding in the screen.

#### 3. Delete:

Delete the selected program by pressing on the button “Delete” with rotary/push knob.

If a selected program is deleted by pressing on menu option “Delete” with rotary/push knob, all the program parameters will be emptied. The symbol (  ) disappears.

#### 4. View:

View the “Speed (rpm)-Timer (hh:mm:ss)” graph of the selected program by pressing on the button “View” with rotary/push knob.

#### 5. Rename:

Rename the selected program by pressing on the button “Rename” with rotary/push knob.

### Ramp:

In this menu, 5 user-defined "Ramp" files can be created. In every ramp file, the user can define below parameters:

1. Mode: The user can define the control mode as "Accurate", "Balance" or "Fast". For details, see "Accuracy" under menu option "Viscosity".
2. Start: The user can define the start speed (0.01 to 200 rpm) for spindle.
3. End: The user can define the end speed (0.01 to 200 rpm) for spindle.
4. Step: The user can define step (2 to 20) for ramp control.
5. Loop Back: The user can define the loop back as "On" or "Off" for the ramp control.

### Stop Condition:

In this menu, the user can define different conditions for stopping the device:

1. Timer: The user can defined a specific time that at which the measurement stops. The device shows the obtained viscosity value on the display.
2. Torque: The user can defined a torque range that at which the measurement stops. The device shows the obtained viscosity value on the display.
3. Temperature: The user can defined a temperature range that at which the measurement stops. The device shows the obtained viscosity value on the display.
4. Viscosity: The user can defined viscosity value that at which the measurement stops. The device shows the obtained viscosity value on the display.
5. None: When this option is activated, the function of "Stop Condition" is disabled.



### **Profile:**

#### Load:

In the "Load" menu, the user can define all setting in last operation as a profile.

#### Delete:

In the "Delete" menu, the user can delete the loaded profile.

#### Rename:

In the "Rename" menu, the user can edit the profile name as required.

**Note:** The profile name can include at maximum 15 letters or numbers.



### **Safety:**

#### Password:

In the "Password" menu, the menu settings can be locked by a 3-digit password.



## Setting:

### Languages:

The "Languages" option allows the user to select the desired language by turning and pressing the rotary/push knob. A tick (✓) indicates the language that is set for the system.

### Units:

The "Units" option allows the user to select the desired unit for displaying the temperature and viscosity. A tick (✓) indicates the unit that is set for the system.

### Display:

The "Display" option allows the user to change the background color of the home screen.

### Sound:

The "Sound" option allows the user to set the volume.

### Factory Settings:

Select the "Factory settings" option by turning and pressing the rotary/push knob. The system requests confirmation to restore the factory settings. Pressing the "OK" button resets all the system settings to the original standard values set at dispatch from the factory (see "Menu structure").

### Communication:

The "Device name" menu option allows you to edit the device name.





### Information:

The "Information" option offers the user an overview of the most important system settings of the device.







## Spindle information

/// Spindle (lo-vi): Viscosity full-scale range based on speed: 1... 200 rpm

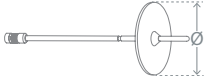
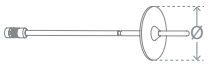
Spindle	lo-vi (mPa·s)
<b>SP-1:</b> (Ø = 18.8 mm) 	30 ... 6.0 x 10 <sup>3</sup>
<b>SP-2:</b> (Ø = 18.7 mm) 	150 ... 30 x 10 <sup>3</sup>
<b>SP-3:</b> (Ø = 12.6 mm) 	600 ... 120 x 10 <sup>3</sup>
<b>SP-4:</b> (Ø = 3.2 mm) 	3 x 10 <sup>3</sup> ... 600 x 10 <sup>3</sup>

/// Spindle (me-vi/hi-vi I/hi-vi II): Viscosity full-scale range based on speed: 1... 200 rpm

Spindle	me-vi (mPa·s)	hi-vi I (mPa·s)	hi-vi II (mPa·s)
<b>SP-7:</b> (Ø = 46.9 mm) 	200 ... 40 x 10 <sup>3</sup>	400 ... 80 x 10 <sup>3</sup>	1600 ... 320 x 10 <sup>3</sup>
<b>SP-8:</b> (Ø = 34.7 mm) 	500 ... 100 x 10 <sup>3</sup>	1 x 10 <sup>3</sup> ... 200 x 10 <sup>3</sup>	4 x 10 <sup>3</sup> ... 800 x 10 <sup>3</sup>
<b>SP-9:</b> (Ø = 27.3 mm) 	1 x 10 <sup>3</sup> ... 200 x 10 <sup>3</sup>	2 x 10 <sup>3</sup> ... 400 x 10 <sup>3</sup>	8 x 10 <sup>3</sup> ... 1.6 x 10 <sup>6</sup>
<b>SP-10:</b> (Ø = 21.1 mm) 	2 x 10 <sup>3</sup> ... 400 x 10 <sup>3</sup>	4 x 10 <sup>3</sup> ... 800 x 10 <sup>3</sup>	16 x 10 <sup>3</sup> ... 3.2 x 10 <sup>6</sup>
<b>SP-11:</b> (Ø = 14.6 mm) 	5 x 10 <sup>3</sup> ... 1 x 10 <sup>6</sup>	10 x 10 <sup>3</sup> ... 2 x 10 <sup>6</sup>	40 x 10 <sup>3</sup> ... 8 x 10 <sup>6</sup>
<b>SP-12:</b> (Ø = 3.2 mm) 	20 x 10 <sup>3</sup> ... 4 x 10 <sup>6</sup>	40 x 10 <sup>3</sup> ... 8 x 10 <sup>6</sup>	160 x 10 <sup>3</sup> ... 32 x 10 <sup>6</sup>

# Interfaces and outputs

The device can be operated by computer via an RS 232 or USB port using labworldsoft® laboratory software.

The device software can also be updated with a PC via the RS 232 or USB port.

**Note:** Please comply with the system requirements together with the operating instructions and help section included with the software.

## /// USB interface:

The Universal Serial Bus (USB) is a serial bus for connecting the device to the PC. Equipped with USB devices can be connected to a PC during operation (hot plugging). Connected devices and their properties are automatically recognized. The USB port can also be used to update firmware.

## /// USB device drivers:

First, download the latest driver for IKA devices with USB port from:

<http://www.ika.com/ika/lws/download/usb-driver.zip>

Install the driver by running the setup file. Then connect the IKA device through the USB data cable to the PC.

The data communication is via a virtual COM port.

## /// RS 232 interface:

Configuration

- › The functions of the interface connections between the device and the automation system are chosen from the signals specified in EIA standard RS 232 in accordance with DIN 66 020 Part 1.
- › For the electrical characteristics of the interface and the allocation of signal status, standard RS 232 applies in accordance with DIN 66 259 Part 1.
- › Transmission procedure: asynchronous character transmission in start-stop mode.
- › Type of transmission: full duplex.
- › Character format: character representation in accordance with data format in DIN 66 022 for start-stop mode. 1 start bit; 7 character bits; 1 parity bit (even); 1 stop bit.
- › Transmission speed: 9600 bit/s.
- › Data flow control: none
- › Access procedure: data transfer from the device to the computer takes place only at the computer's request.

## /// Command syntax and format:

The following applies to the command set:

- › Commands are generally sent from the computer (Master) to the device (Slave).
- › The device sends only at the computer's request. Even fault indications cannot be sent spontaneously from the device to the computer (automation system).
- › Commands are transmitted in capital letters.
- › Commands and parameters including successive parameters are separated by at least one space (Code: hex 0x20).
- › Each individual command (incl. parameters and data) and each response are terminated with Blank CR LF (Code: hex 0x0d hex 0x0A) and have a maximum length of 80 characters.
- › The decimal separator in a number is a dot (Code: hex 0x2E).

The above details correspond as far as possible to the recommendations of the NAMUR working party (NAMUR recommendations for the design of electrical plug connections for analogue and digital signal transmission on individual items of laboratory control equipment, rev. 1.1). The NAMUR commands and the additional specific IKA commands commissioning serve only as low level commands for communication between the device and the PC. With a suitable terminal or communications program these commands can be transmitted directly to the device. The IKA software package, Labworldsoft®, provides a convenient tool for controlling device and collecting data under MS Windows, and includes graphical entry features, for motor speed ramps for example.

Commands	Function
IN_NAME	Read device name.
RESET	Switch to normal operation mode
IN_PV_3	Read external actual temperature
IN_PV_4	Read the actual speed (rpm)
IN_PV_5	Read the actual torque (M%)
IN_PV_80	Read visicocity
IN_PV_82	Read shear rate
IN_PV_83	Read shear stress
IN_PV_84	Read density
OUT_SP_4 X (X = 0 ... 200)	Adjust the rated speed value
OUT_SP_81 n	Select spindle
START_4	Start the motor
STOP_4	Stop the motor
IN_SOFTWARE_ID	Read software ID and version

### /// Connection between the device and external devices:

PC 1.1 Cable: This cable is required to connect RS 232 port to a PC.



USB 2.0 Cable (A – micro B): This cable is required to connect USB port to a PC.



# Error codes



The fault is shown by an error message on the display if the error occurs.

Proceed as follows in such case:

- › Switch the device off.
- › Carry out corrective measures.
- › Restart the device.

Error message	Cause	Effect	Correction
Error 1	cable or motor disc sensor damaged	motor disc no feedback signal	send back to service
Error 2	cable or spring disc sensor damaged	spring disc no feedback signal	send back to service
Error 4	motor or motor driver damaged	device can't work	send back to service

If the action described fails to resolve the fault or another error code is displayed then take one of the following steps:

- › Contact the service department
- › Send the device for repair, including a short description of the fault.

# Maintenance and cleaning



The device is maintenance-free. It is only subject to the natural wear and tear of components and their statistical failure rate.

## /// Cleaning:

For cleaning disconnect the mains plug!

Dirt	Cleaning agent
Dye	Isopropyl alcohol
Construction material	Water containing tenside / isopropyl alcohol
Cosmetics	Water containing tenside / isopropyl alcohol
Foodstuff	Water containing tenside
Fuel	Water containing tenside
Other materials	Please consult IKA

- › Wear protective gloves during cleaning the device.
- › Electrical device may not be placed in the cleansing agent for the purpose of cleaning.
- › Do not allow moisture to get into the device when cleaning.
- › Before using another than the recommended method for cleaning or decontamination, the user must ascertain with IKA that this method does not destroy the device.

## /// Spare parts order:

When ordering spare parts, please give:

- › machine type,
- › serial number, see type plate,
- › item and designation of the spare part see [www.ika.com](http://www.ika.com),
- › software version.

### /// Repair:

Please send in device for repair only after it has been cleaned and is free from any materials which may constitute a health hazard.

For repair, please request the "**Safety declaration (Decontamination Certificate)**" from IKA or use the download printout of it from IKA website: [www.ika.com](http://www.ika.com).

If you require servicing, return the device in its original packaging. Storage packaging is not sufficient. Please also use suitable transport packaging.

## Accessories

- › Rotavisc lo-vi standard spindle series
- › Rotavisc me-vi standard spindle series
- › VAN-1: Van spindle
- › DINS-1: DIN adapter
- › ELVAS-1: Extremely low viscosity adapter
- › VOLS-1: Low volume adapter
- › SAS-1: Spiral adapter
- › Standard silicon oil CAL-0-5 to CAL-0-10000

For further accessories see [www.ika.com](http://www.ika.com).

# Technical data



<b>General data</b>		
Nominal voltage	VDC	24
Power input	W	24
Motor rating output	W	4.8
Operating mode		Automatic / Manual
Guard rail		lo-vi / me-vi, hi-vi I, hi-vi II
Spindle set		lo-vi / me-vi, hi-vi I, hi-vi II
Support rod diameter	mm	16
Basic container volume	ml	600 (low form beaker)
Interface		USB, RS 232
Permissible ambient temperature	°C	+5 ... +40
Permissible relative humidity	%	80
IP code according to EN 60529		IP 40
Dimensions (W × D × H) (without support rod)	mm	130 × 176 × 305
Weight	kg	2.3
Operation at a terrestrial altitude	m	max. 2000
<b>Viscosity measuring function</b>		
Max. measuring viscosity:	lo-vi	mPa·s
	me-vi	6.0 × 10 <sup>6</sup>
	hi-vi I	40 × 10 <sup>6</sup>
	hi-vi II	80 × 10 <sup>6</sup>
		320 × 10 <sup>6</sup>
Viscosity accuracy	%	± 1 of full scale range
Viscosity repeatability	%	± 0.2 of full scale range
Speed range	rpm	0.01 ... 200
Speed setting accuracy:	in range 0.01... 1 rpm	rpm
	in range 1... 200 rpm	0.01
		0.1
Speed display		TFT LCD
Max. permitted density	kg/dm <sup>3</sup>	9.999
Direction of rotation		counterclockwise
<b>Torque measuring function</b>		
Torque display		TFT LCD
Torque measurement		M%
Overload protection		yes
<b>Temperature measuring function</b>		
Connection for external temperature sensor		PT 100
Working temperature	°C	-100 ... 300
Working temperature display		TFT LCD
Temperature measurement resolution	K	0.1
Temperature measurement accuracy:		
	-100 °C ... +150 °C	K
	150 °C ... +300 °C	0.1+tolerance PT 100 (DIN EN 60751 class A)
		0.2+tolerance PT 100 (DIN EN 60751 class A)
<b>Timer function</b>		
Timer display		TFT LCD
Timer setting range	min.	0 ... 6000
<b>Power supply</b>		
Input voltage	VAC	100 ... 240
	A	0.6
	Hz	50 / 60
Output	VDC	24 VDC
	W	24 LPS (limited power source)
Protection class		2 (double insulated)

## Warranty

In accordance with IKA warranty conditions, the warranty period is 24 months. For claims under the warranty please contact your local dealer. You may also send the machine direct to our factory, enclosing the delivery invoice and giving reasons for the claim. You will be liable for freight costs.

The warranty does not cover worn out parts, nor does it apply to faults resulting from improper use, insufficient care or maintenance not carried out in accordance with the instructions in this operating manual.

## Appendix A “Range coefficient”

Using the “Range coefficient”, the maximum viscosity that can be measured with a specific spindle can be quickly determined.

1. Identify the selected spindle and the viscometer spring sensor (lo-vi/me-vi/hi-vi I/hi-vi II).
2. Find the “Range coefficient” in below table.
3. Divide the range coefficient by the spindle speed.

E.g.: If you choose me-vi viscometer with SP-6 spindle: Range coefficient is 10,000.

At speed of 10 rpm, the maximum viscosity (mPa·s) is  $10,000/10=1,000$  mPa·s

Spindle	lo-vi	me-vi	hi-vi I	hi-vi II
SP-1	6,000	64,000	128,000	512,000
SP-2	30,000	320,000	640,000	2,560,000
SP-3	120,000	1,280,000	2,560,000	10,240,000
SP-4	600,000	6,400,000	12,800,000	51,200,000
SP-5	1,200,000	12,800,000	25,600,000	102,400,000
SP-6	937	10,000	20,000	80,000
SP-7	3,750	40,000	80,000	320,000
SP-8	9,375	100,000	200,000	800,000
SP-9	18,750	200,000	400,000	1,600,000
SP-10	37,500	400,000	800,000	3,200,000
SP-11	93,750	1,000,000	2,000,000	8,000,000
SP-12	375,000	4,000,000	8,000,000	32,000,000
S-SP	98,400	1,050,000	2,100,000	8,400,000
ELVAS-SP	600	6,400	12,800	51,200
DIN-SP-5	1,144	12,200	24,400	97,600
DIN-SP-6	3,420	36,500	73,000	292,000
DIN-SP-7	11,340	121,300	242,600	970,400
VOL-SP-2.1	117,200	1,250,000	2,500,000	10,000,000
VOL-SP-3.8	46,880	500,000	1,000,000	4,000,000
VOL-SP-4.2	120,000	1,280,000	2,560,000	10,240,000
VOL-SP-6.7	3,000	32,000	64,000	256,000
VOL-SP-7.1	4,688	50,000	100,000	400,000
VOL-SP-16.1	480,000	5,120,000	10,240,000	40,960,000
VOL-SP-10.4	23,440	250,000	500,000	2,000,000
VOL-SP-11.0	46,880	500,000	1,000,000	4,000,000
VOL-SP-13.5	93,750	1,000,000	2,000,000	8,000,000
VOL-SP-9.0	30,000	320,000	640,000	2,560,000
VOL-SP-9.4	60,000	640,000	1,280,000	5,120,000

Spindle	lo-vi	me-vi	hi-vi I	hi-vi II
<b>VAN-SP-1</b>	2,456	26,200	52,400	459,600
<b>VAN-SP-2</b>	10,404	111,000	222,000	888,000
<b>VAN-SP-3</b>	50,146	535,000	1,070,000	4,280,000
<b>VAN-SP-4</b>	508,954	5,430,000	10,860,000	43,4440,000

For measuring spindles of SP-1, SP-2, SP-6 and ELVAS-SP, experiment has verified approximate turbulence transition situations in the following conditions:

1. SP-1 lo-vi spindle, 15 mPa·s at 60 rpm, rpm/mPa·s = 4;
2. SP-2 lo-vi spindle, 100 mPa·s at 200 rpm, rpm/mPa·s = 2
3. SP-6 me-vi spindle, 100 mPa·s at 50 rpm, rpm/mPa·s = 0.5
4. ELVAS-SP, 0.85 mPa·s at 60 rpm, rpm/mPa·s = 70.6

If the rpm/mPa·s ratio exceeds above values, turbulent situation may occur to the spindles listed above.

For measuring spindles ranging from VAN-SP-1 to VAN-SP-4:

Artificially higher viscosity readings may be introduced by turbulence at speeds of above 10 rpm.

## Appendix B “ASTM Specifications”

The following ASTM specifications describe the use of IKA viscometers and accessories.

<b>D 115-17</b>	Methods of Testing Varnishes Used for Electrical Insulation
<b>D 789-15</b>	Test Methods for Determination of Relative Viscosity, Melting Point, and Moisture Content of Polyamide (PA)
<b>D 1076-15</b>	Specification for Rubber-Concentrated, Ammonia Preserved, Creamed and Centrifuged Natural Latex
<b>D 1417-16</b>	Methods of Testing Rubber Latices- Synthetic
<b>D 1439-15</b>	Methods of Testing Sodium Carboxymethyl-cellulose
<b>D 1824-16</b>	Test Method for Apparent Viscosity of Plastisols and Organosols at Low Shear Rates by Brookfield Viscometer
<b>D 2196-15</b>	Test Methods for Rheological Properties on Non-Newtonian Materials by Rotational (Brookfield) Viscometer
<b>D 2364-15</b>	Standard Methods of Testing Hydroxyethyl-cellulose
<b>D 2556-14</b>	Test Method for Apparent Viscosity of Adhesives Having Shear Rate Dependent Flow Properties
<b>D 2669-16</b>	Test Method for Apparent Viscosity of Petroleum Waxes Compounded With Additives (Hot Melts)
<b>D 2983-17</b>	Test Method for Low-Temperature Viscosity of Automotive Fluid Lubricants Measured by the Brookfield Viscometer
<b>D 3236-15</b>	Test Method for Apparent Viscosity of Hot Melt Adhesives and Coating Materials (Reapproved 1999)
<b>D 3468-99</b>	Standard Specification for Liquid- Applied Neoprene and Chlorosulfonated Polyethylene Used in Roofing and Waterproofing
<b>D 3716-14</b>	Method of Testing Emulsion Polymers for Use in Floor Polishes
<b>D 3791-90</b>	Standard Practice for Evaluating the Effects of Heat on Asphalts
<b>D 4046-14</b>	Test Method for Viscosity of Chemical Grouts by the Brookfield Viscometer (Laboratory Method)
<b>D 4889-15</b>	Standard Test Methods for Polyurethane Raw Materials: Determination of Viscosity of Crude or Modified Isocyanates
<b>D 5018-89</b>	Standard Test Method for Shear Viscosity of Coal-Tar and Petroleum Pitches (Reapproved 1999)
<b>D 5133-01</b>	Standard Test Method for Low Temperature, Low Shear Rate, Viscosity/Temperature Dependence of Lubricating Oils Using a Temperature-Scanning Technique
<b>D6267-13</b>	Standard Test Method for Apparent Viscosity of Hydrocarbon Resins at Elevated Temperatures
<b>D6895-06</b>	Standard Test Method for Rotational Viscosity of Heavy Duty Diesel Drain Oils at 100°C
<b>D4402-15</b>	Standard Test Method For Viscosity Determination Of Asphalt At Elevated Temperatures Using A Rotational Viscometer
<b>D6080-12a</b>	Standard Practice for Defining the Viscosity Characteristics of Hydraulic Fluids



designed for scientists

---

**IKA-Werke GmbH & Co. KG**

Janke & Kunkel-Straße 10, 79219 Staufen, Germany

Phone: +49 7633 831-0, Fax: +49 7633 831-98

eMail: [sales@ika.de](mailto:sales@ika.de)

---

**USA**

IKA Works, Inc.

Phone: +1 910 452-7059

eMail: [sales@ika.net](mailto:sales@ika.net)

**KOREA**

IKA Korea Ltd.

Phone: +82 2 2136 6800

eMail: [info@ika.kr](mailto:info@ika.kr)

**BRAZIL**

IKA Brasil

Phone: +55 19 3772 9600

eMail: [sales@ika.net.br](mailto:sales@ika.net.br)

**MALAYSIA**

IKA Works (Asia) Sdn Bhd

Phone: +60 3 6099-5666

eMail: [sales.lab@ika.my](mailto:sales.lab@ika.my)

**CHINA**

IKA Works Guangzhou

Phone: +86 20 8222 6771

eMail: [info@ika.cn](mailto:info@ika.cn)

**POLAND**

IKA Poland Sp. z o.o.

Phone: +48 22 201 99 79

eMail: [sales.poland@ika.com](mailto:sales.poland@ika.com)

**JAPAN**

IKA Japan K.K.

Phone: +81 6 6730 6781

eMail: [info\\_japan@ika.ne.jp](mailto:info_japan@ika.ne.jp)

**INDIA**

IKA India Private Limited

Phone: +91 80 26253 900

eMail: [info@ika.in](mailto:info@ika.in)

**ENGLAND**

IKA England LTD.

Phone: +44 1865 986 162

eMail: [sales.England@ika.com](mailto:sales.England@ika.com)

---

Discover and order the fascinating products of IKA online:  
[www.ika.com](http://www.ika.com)



IKAworldwide



IKAworldwide /// #lookattheblue



@IKAworldwide

---

Technical specifications may be changed without prior notice.

20000021623\_Rotavisc control\_EN\_102018\_web